

**READ ALL INSTRUCTIONS BEFORE USING THIS PUMP. FAILURE TO READ AND FOLLOW THE INSTRUCTIONS IN THIS USER MANUAL COULD CAUSE DEATH OR SERIOUS INJURY.**

## Table of Contents

GENERAL INFORMATION .....	1, 2
WARNINGS .....	3
PUMP COMPONENTS .....	4
BREATHING AIR REQUIREMENTS .....	4
<b>ASSEMBLY AND INSTALLATION</b>	
Assembling the Free-Air Pump .....	4
How Air Motor Works .....	4
How Motor Drives Pump .....	4
How Pump Supplies Air .....	4, 5
Installation .....	5
OPERATING THE FREE-AIR PUMP .....	5, 6
<b>MAINTAINING THE FREE-AIR PUMP</b>	
Maintaining the Air Motor .....	6
Maintaining the Pump Compressor .....	6
Ensuring Pump Performance .....	6
TROUBLESHOOTING GUIDE .....	6, 7
REPLACEMENT PARTS .....	7
PUMP WARRANTY .....	7
AIR FILTER REPLACEMENT SCHEDULE .....	7, 8
AUTHORIZATION FOR RETURNED GOODS .....	8

## General Information

Bullard Free-Air Pumps MUST be located in a clean air environment where at least Grade D breathable air is assured at all times. Bullard Free-Air Pumps transfer ambient air from a clean air location, where at least Grade D breathable air can be assured at all times, to workers wearing Type C or CE continuous flow airline respirator hoods or tight fitting half or full face masks. Only NIOSH approved respirators should be used with this pump.

The ambient air is filtered through a medium efficiency inlet air filter and a carboline outlet filter before entering the respirator's air supply hose.

Bullard Free-Air Pumps are oil-less and have rotary carbon vanes. They produce no carbon monoxide, oil vapors, oil mist or moisture. They do not require expensive carbon monoxide monitors, high temperature alarms or other standard supplied air pressure monitoring equipment. No calibration is required.

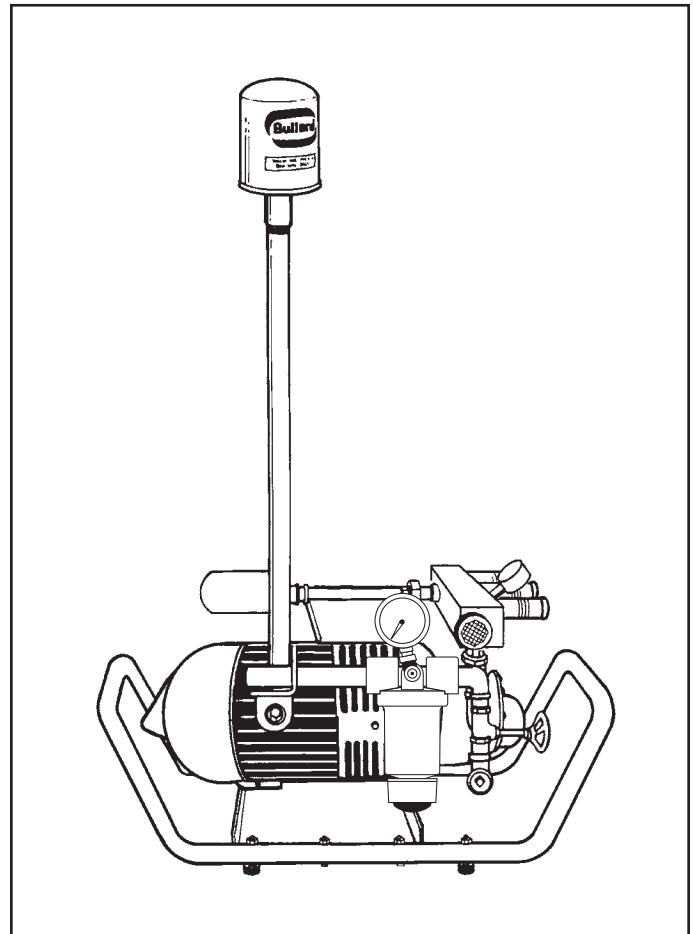

### NOTE

Industrial High Pressure Compressed Air (psig) determines horsepower of air motor which directly affects output air pressure and output air volume coming from the Free Air Pump Compressor that is sent to the Respirator System.

### Model ADP3CA Pump - (Quality Check at Factory) Incoming Drive-Air Pressure Maintained at 80 psig

Pump's Output Air Pressure (psig)	Pump's Output Air Volume (cfm)*
11	16 to 18

\* Assumes that no air is being dumped from the pressure relief valve and that pump's drive-air pressure is maintained at 80 psig.

\*\* It should be noted that the minimum air flow required for each tight-fitting mask style respirator is four (4) cfm. A minimum air flow of six (6) cfm is required for each hood style respirator. These air flow ratings are the NIOSH Required Minimums per OSHA Standard 42 CFR Part 84, Subpart J, Table 8, Type C or CE Respirator System.

\*\*\* Quality Check at Factory occurs on every pump, built by Bullard, to assure air flow and pressure parameters are reliable.

### Model ADP3CA Pump Performance Table Incoming Drive-Air Pressure Maintained at 85 psig

Pump's Output Air Pressure (psig)	Pump's Output Air Volume (cfm)*
5	22 to 24
10	18 to 20
15	13 to 15
20	6 to 8

\* Assumes that no air is being dumped from the pressure relief valve and that pump's drive-air pressure is maintained at 85 psig.

\*\* It should be noted that the minimum air flow required for each tight-fitting, mask-style respirator is four (4) cfm. A minimum airflow of six (6) cfm is required for each hood-style respirator. These air flow ratings are the NIOSH Required Minimums per OSHA Standard 42 CFR Part 84, Subpart J, Table 8, Type C or CE Respirator System.

### Model ADP3CA Pump Performance Table Incoming Drive-Air Pressure Maintained at 95 psig

Pump's Output Air Pressure (psig)	Pump's Output Air Volume (cfm)*
5	23 to 25
10	19 to 21
15	14 to 16
20	7 to 9

\* Assumes that no air is being dumped from the pressure relief valve and that pump's drive-air pressure is maintained at 95 psig.

\*\* It should be noted that the minimum air flow required for each tight-fitting mask style respirator is four (4) cfm. A minimum airflow of six (6) cfm is required for each hood-style respirator. These air flow ratings are the NIOSH Required Minimums per OSHA Standard 42 CFR Part 84, Subpart J, Table 8, Type C or CE Respirator System.

# ADP3CA Free-Air® Pump User Manual

## WARNING

READ, UNDERSTAND AND FOLLOW ALL INSTRUCTIONS IN THIS MANUAL BEFORE USING FREE-AIR PUMP MODEL ADP3CA. FAILURE TO OPERATE THIS PUMP IN ACCORDANCE WITH THE INSTRUCTIONS CONTAINED IN THIS MANUAL MAY RESULT IN DEATH OR SERIOUS INJURY TO THE RESPIRATOR WEARER. IMPROPER USE MAY ALSO CAUSE CERTAIN LIFE-THREATENING DELAYED LUNG DISEASES INCLUDING BUT NOT LIMITED TO SILICOSIS, PNEUMOCONIOSIS, OR ASBESTOSIS.

1. LOCATE THE PUMP'S INLET AIR FILTER IN A PLACE WHERE THERE IS A CONTINUOUS SUPPLY OF AT LEAST GRADE D BREATHABLE AIR AT ALL TIMES, AS DEFINED BY THE COMPRESSED GAS ASSOCIATION COMMODITY SPECIFICATION G-7.1, AND AS SPECIFIED BY FEDERAL LAW 42 CFR PART 84, SUBPART J, 84.141(B), AND 29 CFR PART 1910, SUBPART I, 1910.134(I). THE PUMP WILL NOT REMOVE TOXIC GASES OR OTHER CONTAMINANTS FROM THE INCOMING AIR THAT IT TRANSFERS TO THE RESPIRATOR WEARER. THIS PUMP MUST BE SUPPLIED WITH AT LEAST GRADE D BREATHABLE AIR AT ALL TIMES.

SEE THE BREATHING AIR REQUIREMENTS SECTION ON PAGE 4 FOR SPECIFIC DETAILS ON BREATHING AIR QUALITY.

2. THIS PUMP WILL SUPPLY AT LEAST THE REQUIRED MINIMUM VOLUME OF AIR (6 CFM FOR HOODS OR 4 CFM FOR TIGHT FITTING MASKS) TO LOW PRESSURE, AIRLINE RESPIRATORS. THE RESPIRATORS MUST BE APPROVED BY MSHA/NIOSH TO OPERATE AT LESS THAN 20 PSIG.

BE SURE THAT THE PUMP'S OUTLET PRESSURE, MEASURED BY THE PRESSURE GAUGE ON THE PUMP, IS MAINTAINED ABOVE THE MINIMUM PRESSURE SETTING REQUIRED BY THE RESPIRATOR MANUFACTURER AND APPROVED BY MSHA/NIOSH.

TO BE ASSURED YOUR RESPIRATOR CAN BE USED WITH THIS PUMP, REFER TO THE SECTION IN THE RESPIRATOR'S USER MANUAL FOR THE RESPIRATOR'S APPROVED PRESSURE RANGE AND PERMISSIBLE AIR SUPPLY HOSE LENGTH.

IF YOU HAVE ANY QUESTIONS ABOUT WHETHER OR NOT YOUR RESPIRATOR IS COMPATIBLE WITH THIS PUMP, CONTACT BULLARD'S CUSTOMER SERVICE DEPARTMENT AT 877-BULLARD (285-5273).

3. AIRLINE RESPIRATORS USED WITH THIS PUMP MUST NOT BE WORN IN ANY ATMOSPHERE IMMEDIATELY DANGEROUS TO LIFE OR HEALTH (IDLH) OR FROM WHICH THE WEARER CANNOT ESCAPE WITHOUT THE USE OF THE RESPIRATOR.
4. WHEN CONNECTING YOUR RESPIRATOR TO THE FREE-AIR PUMP, USE ONLY THE AIR SUPPLY HOSE AND COUPLINGS REQUIRED BY THE RESPIRATOR MANUFACTURER AND LISTED ON THE NIOSH APPROVAL LABEL FOR THE RESPIRATOR. THE APPROVAL LABEL IS INCLUDED IN THE RESPIRATOR'S USER MANUAL.

USE OF NON-APPROVED HOSE OR COUPLINGS WILL VOID THE RESPIRATOR'S MSHA/NIOSH APPROVAL AND COULD REDUCE THE AIR FLOW TO THE RESPIRATOR, WHICH COULD CAUSE DEATH OR SERIOUS INJURY OR LIFE-THREATENING DELAYED LUNG DISEASE INCLUDING BUT NOT LIMITED TO SILICOSIS, PNEUMOCONIOSIS, OR ASBESTOSIS.

5. DO NOT MODIFY OR ALTER THIS PUMP IN ANY MANNER. USE ONLY APPROVED BULLARD FREE-AIR PUMP COMPONENTS AND REPLACEMENT PARTS ON THE PUMP.

FAILURE TO USE APPROVED BULLARD COMPONENTS AND REPLACEMENT PARTS VOIDS ALL BULLARD WARRANTIES AND COULD CAUSE DEATH OR SERIOUS INJURY OR LIFE-THREATENING DELAYED LUNG DISEASE INCLUDING BUT NOT LIMITED TO SILICOSIS, PNEUMOCONIOSIS, OR ASBESTOSIS.

6. IF YOU HAVE ANY QUESTIONS CONCERNING THE USE OF THIS PUMP OR YOUR RESPIRATOR, OR YOU ARE NOT SURE THE INLET AIR FILTER IS LOCATED IN AN ENVIRONMENT CONTAINING CLEAN, AT LEAST GRADE D BREATHABLE AIR, ASK YOUR SUPERVISOR BEFORE USING.

ALL INSTRUCTIONS FOR THE USE AND CARE OF THIS PRODUCT MUST BE SUPPLIED TO YOU BY YOUR EMPLOYER AS RECOMMENDED BY THE MANUFACTURER AND AS REQUIRED BY FEDERAL LAW 29 CFR PART 1910, SUBPART I, 1910.134.

FOR TECHNICAL ASSISTANCE OR ADDITIONAL COPIES OF THIS MANUAL, CALL OR WRITE TO:

BULLARD  
1898 SAFETY WAY  
CYNTHIANA, KY 41031-9303  
TOLL-FREE: 877-BULLARD (285-5273)  
PHONE: 859-234-6616  
FAX: 859-234-8987

## Model ADP3CA Pump Components

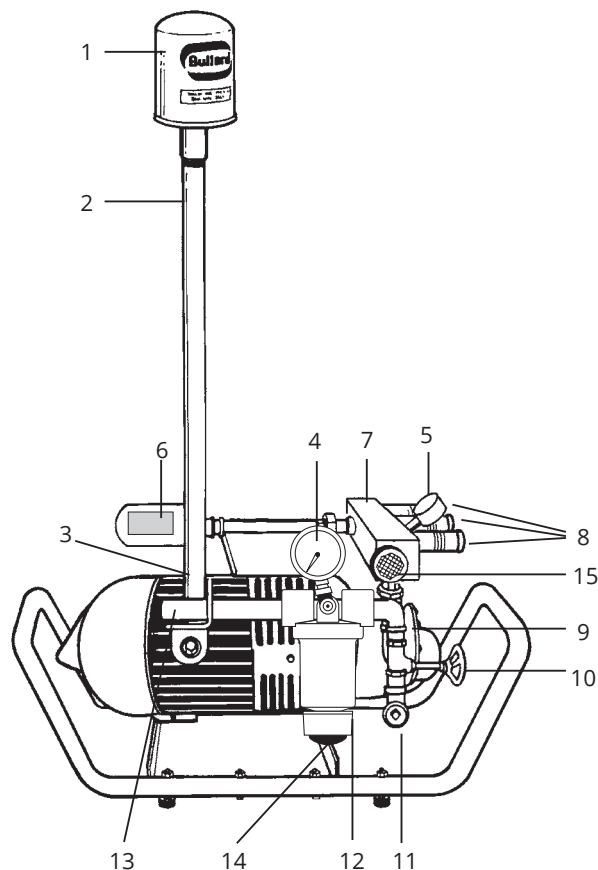

1. Inlet Air Filter 23611
2. Air Inlet Stand Pipe
3. Threaded Air Inlet Port
4. Gauge, Drive Air Pressure (0-200 psig) S09853
5. Gauge, Outlet Air Pressure (0-30 psig) S19683
6. Outlet Filter Cartridge S17101
7. Heat Exchanger
8. Quick-Disconnect Couplers, Female (1/4" Industrial Interchange) V15
9. Air Motor
10. Throttle Valve
11. Plug
12. Pressure Regulator
13. Drive Air Inlet
14. Regulator Knob
15. Motor Exhaust Muffler

### Breathing Air Requirements Air Quality

The Free-Air pump's inlet air filter **MUST** be located in a place where there is at least Grade D breathable air at all times.

The ambient air drawn into the inlet filter must meet at least the requirements for Grade D breathable air as described in the Compressed Gas Association Commodity Specifications G-7.1 and as specified by Federal Law 42 CFR Part 84, Subpart J, 84.141(b) and 29 CFR Part 1910, Subpart I, 1910.134(i).

The requirements of Grade D breathable air include:

- Oxygen.....19.5 - 23.5%
- Hydrocarbons (condensed) in mg/m<sup>3</sup> of gas.....5 mg/m<sup>3</sup> maximum
- Carbon Monoxide .....10 ppm maximum
- Carbon Dioxide.....1,000 ppm maximum
- Odor .....No detectable odor
- No toxic contaminants at levels which would make the air unsafe to breathe.

Refer to the C.G.A. Commodity Specification G-7.1 for complete details. (WWW.CGANET.COM)

### Assembly and Installation

For the specific location of the pump components referred to below, see the list of pump components to the left.

#### Assembling the Free-Air Pump

1. Remove assembly from plywood shipping board and attach four rubber feet through four holes in skid.
2. Install stand pipe (2), and Inlet Air Filter (1) into threaded air inlet port (3).
3. Make sure the pump's inlet air filter is located in a clean, uncontaminated location where at least Grade D breathable air is assured at all times.

If the inlet air filter cannot be placed at a source containing clean, at least Grade D breathable air, install Bullard's 50 foot Inlet Extension Hose Kit (Part No. V50IN) to the pump's inlet port. See the directions shipped with the Extension Hose Kit for assembly instructions.

If clean, at least Grade D breathable air cannot be guaranteed at all times within this 50 foot reach, you may add up to five additional lengths of 50 foot Extension Hose (Part No. V50EX).

Therefore, you may place your Inlet Filter up to 300 feet away from the pump. **DO NOT ADD MORE THAN 300 FEET OF INLET EXTENSION HOSE TO THE PUMP.**

#### How Air Motor Works

1. Industrial High Pressure Compressed air enters through the air-motor drive AIR INLET (13), passes through PRESSURE REGULATOR (12); where pressure is controlled.

Air pressure is adjusted with REGULATOR KNOB (14) and is read on GAUGE (4) (NOTE: 80 psig to 110 psig during operation is normal for this motor).

2. Air is exhausted through the air-motor drive MOTOR EXHAUST MUFFLER (15) to atmosphere.

#### How Motor Drives Pump

Motor drives pump through a flexible coupler. There are no belts to maintain or tighten.

#### How Pump Supplies Air

At least Grade D breathable air must be supplied to PUMP INLET AIR FILTER (1) at all times (See Breathing Air Requirements in the section above).

The pump draws in air using four sliding carbon vanes set in a rotor, and discharges it under low pressure out of discharge port.

# ADP3CA Free-Air® Pump User Manual

Air passes through Bullard's CARBOFINE OUTLET FILTER CARTRIDGE (6) located inside OUTLET FILTER HOUSING.

Bullard's CARBOFINE outlet filter is triple wrapped with activated carbon media and has a rayon overwrap.

The properties of this filter include:

•99.97% D.O.P. EFFICIENCY (.3-.6 MICRON SIZE PARTICLES)

❗ **NOTE:** Change this outlet filter cartridge at least every 200 running hours.

Low Pressure Supplied Air is sent through one, two, or three COUPLERS (8) to Niosh Approved Respirator Systems being used.

❗ **NOTE:** The three 1/4" Industrial Interchange quick-disconnect couplers are supplied with the factory packed unit.

## Installation

❗ **NOTE:** For the Air Motor Inlet Air, use an appropriate size hose from compressor to pump; 1" or 3/4" internal diameter is best. A larger diameter compressed air hose may be required depending on operating conditions and length of compressed air line.

The incoming industrial high pressure compressed air must have enough capacity to continuously supply at least 85 cfm of air at 95 psig to drive the pump at its rated capacity.

## ❗ CAUTION

Air Motor requires an oil lubrication rate of 1 drip per minute during operation. (SAE 10W motor oil or equivalent is required to protect sliding vanes inside the air motor rotor body.) The ADP3CA is NOT supplied with this Lubricator Drip Module.

1. Close THROTTLE VALVE (10).
2. ATTACH HOSE WITH RESPIRATORS CONNECTED TO AIR OUTLETS (8) ON PUMP.
3. Connect air supply to pump.
4. Adjust AIR REGULATOR so COMPRESSED AIR GAUGE (4) reads 95 psig.
5. Pump is ready to run. Open THROTTLE VALVE (10), build up speed and idle for a few minutes.
6. Adjust THROTTLE VALVE (10) to run pump at desired psig on OUTLET AIR PRESSURE GAUGE (5).
7. Adjust RELIEF-VALVE as follows:

❗ **NOTE:** The RELIEF VALVE is preset at the factory to "bleed off" at 25 psig. Adjustments to this "bleed off" setting can be made following the sequence below:

(Refer to Figure below during adjustments)

- a. Loosen lock nut.
- b. Pinch off respirator air supply hose to create back pressure.
- c. Speed up motor by opening throttle valve.
- d. Adjust relief-valve to "bleed off" at a pressure 1 or 2 psig above that required by respirator.
- e. Slow down motor and check that no air "bleeds" below required pressure.
- f. Maximum output operating pressure is now reset to the new pressure setting.
- g. Tighten lock nut to finish.

❗ **NOTE:** Pump will reach 150° - 200° F during normal running conditions.

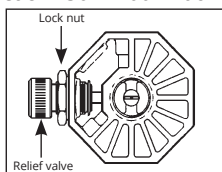

## Operating the Free-Air Pump

### ⚠ WARNING

THE RESPIRATOR USER MUST NOT ENTER THE CONTAMINATED WORK AREA UNTIL ALL OF THE FOLLOWING STEPS HAVE BEEN COMPLETED. FAILURE TO FOLLOW THESE INSTRUCTIONS CAN CAUSE DEATH OR SERIOUS INJURY OR LIFE-THREATENING DELAYED LUNG DISEASE INCLUDING BUT NOT LIMITED TO SILICOSIS, PNEUMOCONIOSIS, OR ASBESTOSIS.

1. Analyze the atmosphere at the location of the pump's air inlet filter. The inlet filter should be located in a clean, uncontaminated location where at least Grade D breathable air is assured at all times. The pump is equipped with a 2 ft. stand pipe to keep the clean air intake away from the air motor exhaust port.

If the inlet filter cannot be placed at a source containing clean, at least Grade D breathable air, install Bullard's 50 foot Inlet Extension Hose Kit (Part No. V50IN) to the pump's inlet port. See the directions shipped with the Extension Hose Kit for assembly instructions.

If a minimum of Grade D breathable air cannot be guaranteed at all times within this 50 foot reach, up to five (5) additional lengths of 50 foot Extension Hose (Part No. V50EX) may be added.

Therefore, the inlet filter may be placed up to 300 feet away from the pump. **DO NOT ADD MORE THAN 300 FEET OF INLET EXTENSION HOSE TO THE PUMP.**

2. Be sure you have read and followed all instructions for assembly and installation of the ADP3CA pump on pages 4 and 5.
3. Pump Model ADP3CA will operate sitting on its four rubber mounts. It does not need to be bolted down.
4. Assemble your MSHA/NIOSH-approved respirator by following the manufacturer's instructions as described in the respirator's User Manual. Be sure the pump's outlet pressure, measured by the pressure gauge on the pump, is greater than the minimum MSHA/NIOSH approved pressure required to operate the respirator system.
5. Connect the respirator manufacturer's approved air supply hose(s) to the quick-disconnect Outlet Coupling(s) on the pump.

### A. OUTLET COUPLING

The pump is equipped with three (3) 1/4" Industrial Interchange quick-disconnect couplers (Part No. V15).

### B. CONNECTING AIR SUPPLY HOSE(S) WITHOUT 1/4" QUICK-DISCONNECT FITTINGS

If your respirator's approved air supply hose will not attach to the pump's standard 1/4" Industrial Interchange Outlet Couplings, (see above) the hose fitting can be adapted to the pump by converting the pump's quick-disconnect outlet to 3/8" female NPT with the installation of one or more of the following adaptors.

Part No. V17 - Converts SINGLE 1/4" quick disconnect outlet to SINGLE 3/8" female NPT pipe thread.

Use Teflon tape or pipe thread sealer to ensure an air tight seal.

A variety of quick-disconnect fittings may then be used to connect the air supply hose to the 3/8" outlet adaptor. Contact your respirator's manufacturer for the proper fitting (Hansen, Parker, Snap-Tite, Schrader, etc.)

6. Before connecting your respirator system to the air supply hose, turn the pump on. Allow the air to flow through the pump and hose for a few minutes to purge or expel any hose odors or moisture that may have accumulated inside the hose.

7. Connect the respirator system to the air supply hose using the quick-disconnect fittings.
8. Set the pump's outlet pressure to within the respirator's approved pressure range by adjusting the THROTTLE VALVE (10).
9. With the air flowing, put on the respirator by following the directions in the respirator manufacturer's User Manual.

YOU ARE NOW READY TO ENTER THE WORK AREA.

10. When finished working, leave the work area wearing the respirator with the air still flowing. Once outside the contaminated area, and in a clean air environment containing at least Grade D breathable air, remove the respirator, turn the pump off, then disconnect the air supply hose using the quick-disconnect couplings.

See the respirator's User Manual for proper inspection, maintenance and storage procedures for the respirator you are using.

## Maintaining the Free-Air Pump

FOR THE PUMP TO OPERATE AT ITS OPTIMUM PERFORMANCE LEVEL, THE FOLLOWING ROUTINE MAINTENANCE PROCEDURES MUST BE PERFORMED.

FOR THE SPECIFIC LOCATION OF THE PUMP COMPONENTS REFERRED TO BELOW, SEE THE LIST OF PUMP COMPONENTS ON PAGE 4.

### Maintaining the Air Motor

The air motor is a rotary 4-vane type. The vanes require no adjustment and will last 5,000-10,000 hours if properly maintained.

1. Flush MOTOR (9):

If motor is sluggish or ineffective, flush with GAST AH255D SAFETY SOLVENT. (DO NOT USE KEROSENE OR SIMILAR CHEMICALS)

Use the following directions to flush the motor:

- a. Shut-off the pressure into the air motor and disconnect the airline from the DRIVE AIR INLET (13).
- b. Locate the pump in a safe area. Solvent will spray from the exhaust port during flushing. Protect your face and eyes from the spray.
- c. Remove the PLUG (11) and spray several ounces of solvent into the opening.
- d. Replace the PLUG, reconnect the airline back to the DRIVE AIR INLET. Turn the pressure back on. Run the pump at a very low speed (10-20 RPM) for approximately one minute or until all the solvent is flushed.

**NOTE:** Motor bearings are grease packed and sealed. They require no maintenance.

### Maintaining The Pump Compressor

Pump compressor is rotary 4 vane type. The vanes require no adjustment and will last 5,000 to 10,000 hours if properly maintained.

1. Maintain FILTERS

- Dirty filters restrict outlet air flow and can cause the motor to overload or cause premature pump failure.
- Replace CARBOFINE OUTLET FILTER CARTRIDGE (6) at least once every 200 running hours (Part No. S17101).
- Replace INLET FILTER (1) at least once every 500 running hours to maintain proper pressure and full air flow. To check the filter - while running the pump, momentarily remove the FILTER (1) from the INLET PIPE (2). If the motor speeds up or the outlet pressure shown on GAUGE (5) increases, the filter needs replacement.

2. Flush PUMP if necessary

Should dirt, foreign particles, moisture or oil be permitted to

enter, the pump compressor, the vanes will become sluggish, resulting in a lowering of outlet air pressure. Flush the pump with GAST AH255D SAFETY SOLVENT. (DO NOT USE KEROSENE OR SIMILAR CHEMICALS).

Pump should be operated for at least a few minutes every one to two weeks to reduce the likelihood of rust film forming in the rotor.

If pump remains idle in humid environment for some time, FLUSHING may be required to remove rust film in chamber and rotor slots.

Use the following directions to flush the pump compressor:

- a. Turn-off THROTTLE VALVE (10) to stop the pump before flushing.
- b. Before flushing, disassemble and remove the following parts from the pump:
  - Respirator air supply hose(s)
  - Inlet Filter and Air Inlet Stand Pipe
  - Outlet Filter Jar and Outlet Filter
- c. With the pump running, spray several ounces of solvent into the pump's inlet port. Repeat the flushing if necessary.

## ⚠ WARNING

RUN THE PUMP FOR A SUFFICIENT TIME TO PURGE ALL TRACES OF THE SOLVENT BEFORE REPLACING THE FILTERS, RECONNECTING THE AIR SUPPLY HOSE(S) AND USING THE SYSTEM RESPIRATOR.

FAILURE TO FOLLOW THESE INSTRUCTIONS CAN CAUSE DEATH OR SERIOUS INJURY OR LIFE-THREATENING DELAYED LUNG DISEASE INCLUDING BUT NOT LIMITED TO SILICOSIS, PNEUMOCONIOSIS, OR ASBESTOSIS.

3. AVOID EXCESSIVE SPEEDS and PRESSURE

- Avoid running above the 20 psig range for any length of time to prevent pre-mature wearing or over-heating problems to air motor or pump compressor.

**NOTE:** NEVER lubricate this oil-less pump. BEARINGS are grease packed and sealed. They require no further lubrication.

## Ensuring Pump Performance

To make sure your pump will perform properly:

1. Always locate the pump's air inlet in a clean air environment containing at least Grade D breathable air, at all times.
2. DO NOT contaminate inlet air with exhaust air from air motor exhaust port.
3. Change OUTLET FILTER every 200 running hours.
4. Make sure RELIEF VALVE is fully seated (no bleed-off).
5. Always check Respirator Air Supply Hoses to make sure they are free of kinks.
6. Set incoming compressed drive air at 85 psig or higher. Set output air pressure as specified in the respirator user manual.

## Troubleshooting Guide

### OUTLET PRESSURE TOO HIGH

- Adjust THROTTLE VALVE (10)
- Check for kinked air supply hoses
- Reset pressure relief adjustment valve

### OUTLET PRESSURE TOO LOW

- Adjust THROTTLE VALVE to increase motor speed
- Check for clogged INLET FILTER

# ADP3CA Free-Air® Pump User Manual

- Check that outlet filter jar is screwed on tight
- Check for clogged OUTLET FILTER
- Check pressure relief valve and adjust if necessary
- Check drive air inlet pressure
- Check for leaks in air hose
- Verify proper pressure range for your respirator system
- Verify that the respirator and hose are connected when gauge reading is taken
- Check to see that the gauge is functioning properly
- Flush pump with GAST AH255D SAFETY SOLVENT

## RESPIRATOR AIR TEMPERATURE TOO HIGH (ABOVE AMBIENT)

- Air supply hoses coiled too tightly. Uncoil at least the first 50 feet of hose.
- Place portion of air supply hose in large container of ice (e.g. 30 gallon trash can).
- Keep air supply hoses out of direct sunlight or other heat sources.

## Replacement Parts

Part No.	Description
----------	-------------

### OPTIONAL PUMP ACCESSORIES

V50IN	Remote INLET air hose kit (50 feet) with remote inlet filter and pump fittings
V50EX	Extension hose kit (50 foot sections) for above
S17931	GAST AH255D SAFETY SOLVENT (Compressor or air motor)

**NOTE:** If at least Grade D breathable air cannot be assured at all times at the pump, remove inlet filter and attach necessary V50 hose kits to air inlet port. Use up to 300 feet (six lengths) always ending with V50IN kit. These hose kits can provide access to a remote location containing at least Grade D breathable air at all times.

### REPLACEMENT PUMP PARTS

S19683	Gauge, Air (0-30 psig)
S17101	Bullard CARBOFINE outlet filter cartridge
23611	Inlet filter
244852	Outlet filter cover (aluminum cover only)
263552	Outlet filter assembly o-ring
V15	Coupler, 1/4" Industrial Interchange, with male 3/8" NPT
V18	Coupler, 1/4" Schrader with female pipe thread NPT
V19	Coupler, 1/4" Snap-Tite with 1/4" female pipe thread NPT
V17	1/4" Quick-disconnect coupling adaptor, single 3/8" female NPT
S16191	Coupler, 1/2" Industrial Interchange, with 3/8" male NPT
15922	Pump repair kit (includes four carbon vanes, one 23611 inlet filter, one S17101 outlet filter cartridge and instructions)

### AIR MOTOR REPLACEMENT PARTS

S09853	Gauge (0-200 psig)
17761	Motor repair kit (includes four carbon vanes, two motor bearings, vane springs, seal and instructions)

**NOTE:** Pump and motor repair requires use of a 3-prong wheel puller, a gear puller and an experienced mechanic. It may be quicker and less expensive to ship pump and/or motor to GAST Authorized Service Center for repairs. (See Authorization for Returned Goods, page 8)

## Pump Warranty

### Free-Air Pump One Year LIMITED Warranty

Bullard warrants to the original purchaser that the Free-Air Pump will be free of defects in material and workmanship under normal use and service for a period of one (1) year from the date of purchase. Bullard's obligation under this warranty is limited to repairing or replacing, at its option, parts that are returned within the warranty period and that are, after examination, shown to Bullard's satisfaction to be defective, subject to the following limitations.

- Free-Air Pump must be returned to the Bullard factory with shipping charges prepaid.
- Free-Air Pump must not have been misused, subjected to negligent use, or damaged in transport.
- The date of purchase is the start of the one year warranty period. (A copy of the purchaser's original invoice showing the date of purchase is required to validate warranty coverage.)

In no event shall Bullard be responsible for damages for loss of use or other indirect, incidental, consequential or special costs, expenses or damages incurred by the purchaser, notwithstanding that Bullard has been advised of the possibility of such damages.

ANY IMPLIED WARRANTIES, INCLUDING WARRANTIES OF MERCHANTABILITY AND FITNESS FOR A PARTICULAR PURPOSE, ARE SPECIFICALLY EXCLUDED FROM THIS WARRANTY.

Some states do not allow the exclusion or limitation of incidental or consequential damages, or allow limitations on how long an implied warranty lasts, so the above limitations or exclusions may not apply to you. This warranty gives you specific legal rights, and you may have other rights which vary from state to state.

**TO RETURN GOODS:** Written permission must be obtained before returning any material for any reason whatsoever (See Authorization for Returned Goods on page 8).

Products which are obsolete or made to special order may not be returned.

Warranty information can be obtained from:

BULLARD  
1898 SAFETY WAY  
CYNTHIANA, KY 41031-9303  
TOLL-FREE: 877-BULLARD (285-5273)  
PHONE: 859-234-6616  
FAX: 859-234-8987

## Air Filter Replacement Schedule

Regular inspection and replacement of the air filters will prevent extensive and costly pump repairs. Dirty or clogged filters can be responsible for failure of the pump to build up outlet pressure and eventual overheating.

- Replace the Carbofine Outlet Filter Cartridge (Part No. S17101) at least once every 200 running hours or sooner if necessary.

The Carbofine Outlet Filter Cartridge is multi-layered with 40-micron size particles of activated carbon, a sorbent bed with an exposed carbon surface of more than 15,000 square feet.

- D.O.P. Efficiency: (0.3 to 0.6 Micron Particles) 99.97%

- Replace the medium efficiency Inlet Filter (Part No. 23611) at least once every 500 running hours or sooner if necessary.

The Inlet Filter helps keep moisture and particulates out of the pump compressor inlet air flow that could cause premature wear and tear on the pump rotor clearances, and the rotor's sliding carbon vanes.

We recommend the chart on the back page be used to monitor and maintain a routine air filter replacement schedule.



### Authorization for Returned Goods

IMPORTANT: BULLARD WILL DECLINE TO ACCEPT ANY RETURNED GOODS SHIPMENT UNLESS YOU HAVE FIRST FOLLOWED ALL OF THE STEPS OUTLINED BELOW.

To return goods to Bullard for repair, or replacement, whether under the terms of Bullard's warranty provisions or for paid repairs, you MUST:

1. Contact Bullard's Customer Service Department by telephone or in writing at:

BULLARD  
 1898 SAFETY WAY  
 CYNTHIANA, KY 41031-9303  
 TOLL-FREE: 877-BULLARD (285-5273)  
 PHONE: 859-234-6616  
 FAX: 859-234-8987

Describe the nature of the problem you are experiencing. A Bullard Customer Service Representative may contact you for additional information or may attempt to help you resolve the problem over the telephone.

2. Upon determining that the product should be returned, Customer Service will provide you with written permission to return the product to Bullard. This will include information which

must be included on the shipping carton for proper receiving and handling by Bullard. DO NOT return product without first following this procedure.

3. Prior to packing the product for return shipment to Bullard, be certain that it has been fully decontaminated and cleaned of any hazardous materials which may have settled on the product during use. It is against the law to ship hazardous or contaminated materials. Bullard may refuse to accept the return of any product suspected of being contaminated.
4. Products returned, including those under warranty, must be shipped with all transportation charges prepaid. Bullard cannot accept any returned products delivered on a "freight-collect" basis.
5. Material returned will be subjected to factory inspection. Repair work that is deemed necessary, but which is not covered by warranty, will be performed at your expense. Bullard will attempt to provide a best estimate of such charges, but will invoice based upon work performed.

**California Proposition 65 ⚠️ WARNING**  
 Cancer and Reproductive Harm - [www.P65Warnings.ca.gov](http://www.P65Warnings.ca.gov).

**Proposition de la Californie 65 ⚠️ AVERTISSEMENT**  
 Cancer et Troubles de l'appareil reproducteur - [www.P65Warnings.ca.gov](http://www.P65Warnings.ca.gov).

**Propuesta de California 65 ⚠️ ADVERTENCIA**  
 Cáncer y Daño Reproductivo - [www.P65Warnings.ca.gov](http://www.P65Warnings.ca.gov).

## Routine Air Filter Replacement Schedule

CARBOFINE OUTLET FILTER CARTRIDGE (Part No. S17101)			MEDIUM EFFICIENCY INLET FILTER (Part No. 23611)		
Cumulative Pump Operating Hours	Last Filter Replacement Date	Employee Responsible (Initials)	Cumulative Pump Operating Hours	Last Filter Replacement Date	Employee Responsible (Initials)
200			500		
400			1,000		
600			1,500		
800			2,000		
1,000			2,500		
1,200			3,000		
1,400			3,500		
1,600			4,000		
1,800			4,500		
2,000			5,000		

**Bullard Center**  
 2421 Fortune Drive  
 Lexington, KY 40509 • USA  
 877-BULLARD (285-5273)  
 Tel: +1-859-234-6616  
 Fax: +1-859-246-0243

**Americas:  
 E.D. Bullard Company**  
 1898 Safety Way  
 Cynthia, KY 41031-9303  
 Toll free: 877-BULLARD (285-5273)  
 Tel: 859-234-6616  
 Fax: 859-234-8987

**Europe:  
 Bullard GmbH**  
 Dieselstrasse 8a  
 53424 Remagen • Germany  
 Tel: +49-2642 999980  
 Fax: +49-2642 9999829

**Bullard Asia-Pacific Pte. Ltd.**  
 51 Changi Business Park  
 Central 2  
 #03-04 The Signature  
 Singapore 486066  
 Tel: +65 6745 0556



©2023 Bullard. All rights reserved.  
 Free-Air is a registered trademark of Bullard

6094000015D (1123)